



## Engineering Datasheet: Cavity Wall Steel Backbox:

# BACKBOX FS-S

### Application:

For use with the Amina AIWX series of Invisible Loudspeakers. The Backbox FS-S provides a sealed enclosure with additional sound proofing for AIWX loudspeakers installed in cavity walls.

### Description:

The Backbox FS-S is designed for easy installation into cavity wall systems. The box is constructed from 0.8mm thick steel and is lined with a 3mm thick layer of Acoustiblok sound deadening material.

The AIWX loudspeaker mounts onto the layer of foam creating an acoustic seal.

The input cable can be pushed through the rubber grommet on one end of the Backbox FS-S or alternatively a specific cable gland could be fitted to the hole.



### Installing the Backbox:

- Cut a 450 x 350mm hole in the dry-wall. This hole is the same size as the AIWX speaker. It is important not to exceed these dimensions.
- Slide one end of the Backbox FS-S into the hole and up into the cavity.
- Pull the two tabs out to 90 degrees. These will help you to position the Backbox to the hole.
- When correctly positioned, only the mounting foam will be visible.
- Fix the Backbox to the drywall by drilling at least 4 drywall screws per end through the drywall itself and into the flat areas at each end of the box. Ensure the Backbox is fixed securely into position.
- Fix the AIWX speaker to the Backbox using 4 drywall screws. The screws go through the holes at the corners of the speakers and self-tap into the holes in the mounting surface of the Backbox.
- The AIWX speaker face should be flush with the drywall face. Spacing shims are available for non-standard drywall thicknesses.



### Warranty:

The product is maintenance free and is designed to operate reliably for many decades. Correctly installed and operated in accordance with this specification, Amina warrants the AIW5X against defective materials and workmanship for a period of 10 years.



## Technical Specifications:

Dimensions in millimetres

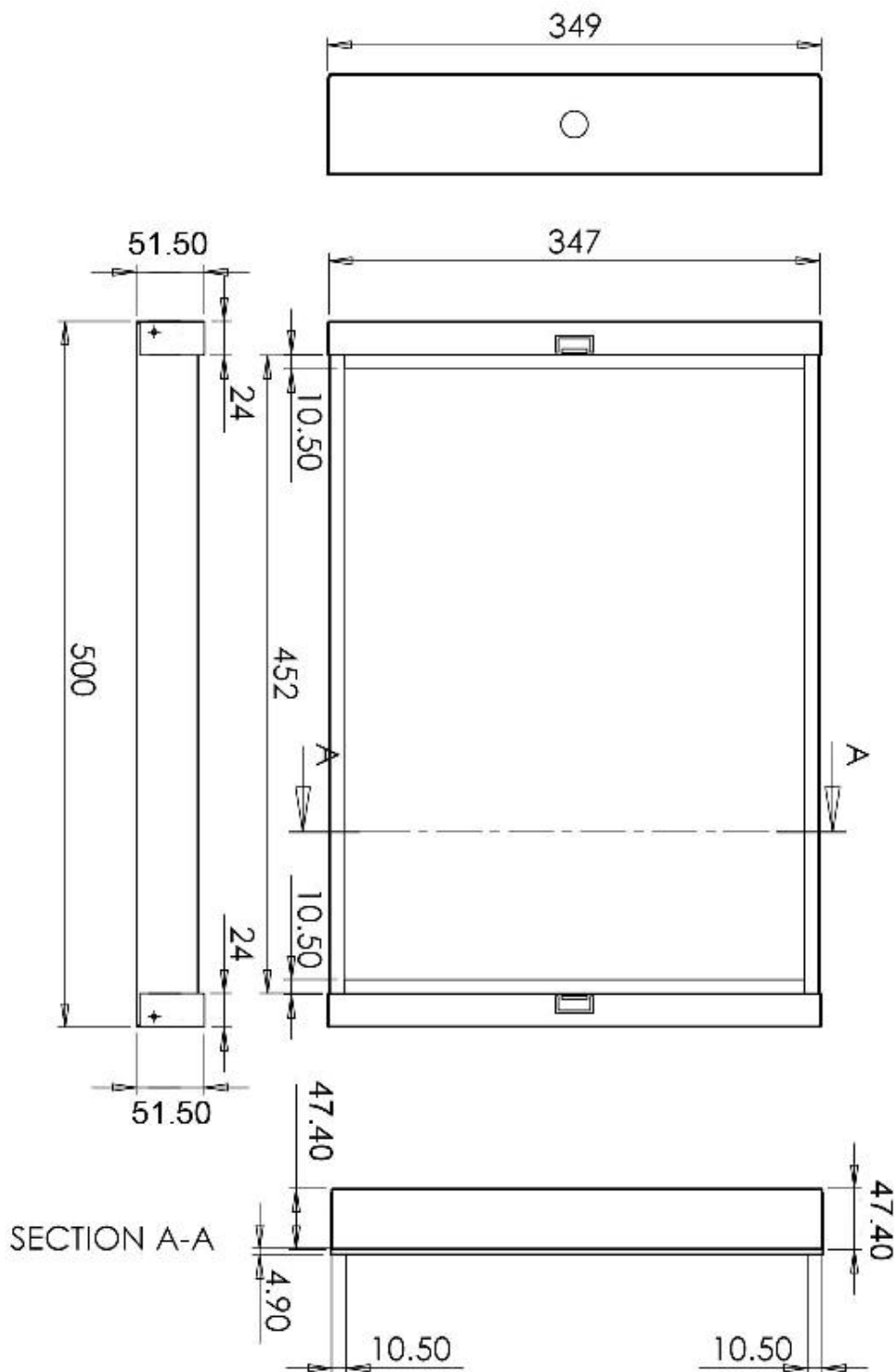

Amina Technologies Ltd,  
Cirrus House, Glebe Road,  
Huntingdon, Cambridgeshire, UK, PE29 7DX

Tel: 00 44 1480 354 390,  
Fax: 00 44 1480 356564  
Email: [inspired@amina.co.uk](mailto:inspired@amina.co.uk),  
Web: [www.amina.co.uk](http://www.amina.co.uk)