

# Invisible Loudspeakers

Hidden Audio Solutions for beautiful living spaces



# SoundUnseen®

HIGH DEFINITION AUDIO REPRODUCTION WITH ZERO VISUAL IMPACT.



## Inspirational Interiors

One of the most striking houses in the North East of England, this period art deco property, situated on the outskirts of Harrogate, has recently been transformed into one of the most desirable properties in the UK. With large open plan living spaces, the interior incorporates the very latest audio-visual, communication and entertainment systems, together with home automation and environmental control functions. The overriding emphasis, from a visual point of view, is of clean contemporary lines, no fuss and minimal technological impact, to create a stunning interior design.

Installed by Lifestyle Technologies of Yarm, the client selected the Amina SoundUnseen® Plaster In-Wall Loudspeakers in a 5.1 surround configuration to work alongside the two, centrally located plasma screens. The location of the full height two storey windows, with magnificent views of the garden, limits wall space and restricts the front left and right channel loudspeaker positions to a very small area immediately adjacent to the side walls.



## The Conventional Solution

Well outside the main listening area, conventional in-wall loudspeakers (complete with visible meshed grilles), positioned here, generate a compromised sound quality due to the immediate reflections of acoustic energy from the side walls. Such reflected energy combines and interferes with the direct energy from the loudspeaker with resulting strange acoustic effects.

Their physical position also means that the main listening area receives less effective off-axis energy, resulting in poor frequency response and limited coverage. Overall the audio quality is poor, with steep and patchy sound level gradients evident within the large open plan space. By the kitchen, for instance, the reproduced sound level is very loud from one channel, but much quieter in the central area.

In conclusion, the system fails to achieve high quality surround sound at any point in the room due to the enormous width compared to its smaller depth.

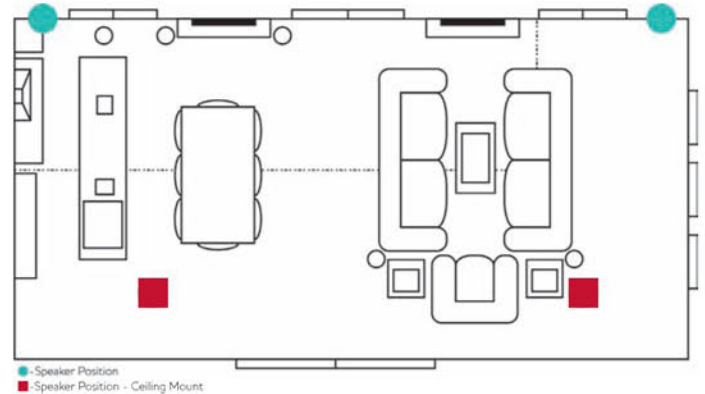

## The SoundUnseen® Solution

Now position Amina SoundUnseen® Plaster In-wall loudspeakers in the same place. Not only do all visual signs of a sound source completely disappear, but the resulting audio quality is astonishing. This is an excellent example of the freedom and flexibility now available to independently position the loudspeaker from the listener. The entire room is filled with high definition surround sound with no more steep sound pressure gradients, whilst the interior is left to be inspirational.

*If you thought you needed to see numerous loudspeakers to have*

If you thought you couldn't have great sound in wet areas, think again!

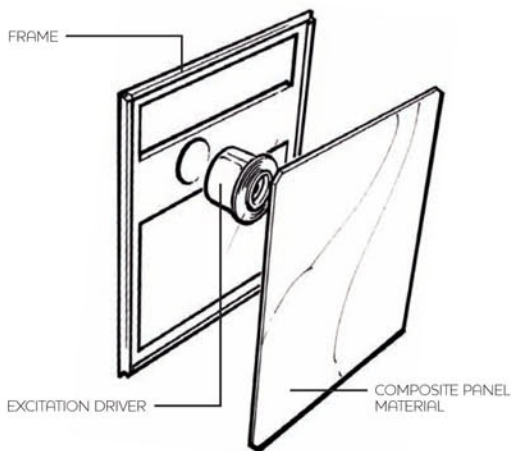

## The Technology

The core element of an Amina Plaster In-wall loudspeaker comprises a specialist lightweight, yet very strong composite panel material, which vibrates in the same way as the bodies of natural musical instruments (for example the acoustic guitar, violin or piano). These vibrations recreate a diffuse source of sound energy which is emitted in a far less directional manner and one capable of filling a space far more evenly than a conventional loudspeaker. This diffuse source creates a high definition sound field over a very wide area ensuring that surround sound or a stereo sound field is heard whatever the room, and wherever the listening position.

The beating heart of an Amina Plaster In-wall loudspeaker is its acoustic 'engine', using the very latest rare earth magnet based, high power vibrational excitation driver(s) (one in the case of the AIW1X, and four in the case of the AIW5X). This allows the AIW5X to handle an incredible 80w of continuous power, generating a massive 105dB of sound with plaster applied. The AIW1X range copes with the most dynamic of sounds, recreating the clarity of individual notes produced by the classical guitar, to the impressive effects generated in modern action movies.

The acoustic engine sets up tiny, but powerful vibrations (you can feel them but cannot see them) in the specialist composite panel material, which are then transferred through the plaster, paint or wallpaper to the very front surface of the wall or ceiling. This in turn vibrates air molecules at its boundary, which then excites more air molecules further away, sending a diffuse, non correlated energy sound wave out into the room.



## Wet Areas

Another great example of how SoundUnseen® technology helps achieve the best audio in a difficult space, both acoustically and environmentally, is evident in the swimming pool, hot tub area or bathroom.

Wet interior environments create two major challenges. The first is acoustic. In most wet areas, the humidity prevents us from having soft furnishings. This leaves us with hard ceramic floors, walls, ceilings, windows and the water itself. All these surfaces act as highly effective mirrors to acoustic energy. As we have all experienced, any noise made in a pool environment tends to echo for a substantial time, creating a general cacophony of sound.

The second problem is the general environmental conditions. The space is saturated with humidity filled with oxidising chemicals designed to keep the pool germ free. This aggressive compound quickly corrodes metal parts and even attacks man-made rubbers and adhesives. Conventional loudspeakers specified for pool use have to be very robust in order to survive, which generally means sound quality is compromised.

The Amina SoundUnseen® In-wall loudspeaker offers a solution to both problems. Once the unit is plastered into the wall structure, the plaster and the coatings applied to it (e.g. paint) isolate the product from any humidity, eliminating corrosion problems. Secondly, the energy wave produced by this technology is not directional and far less phase oriented. Sound reflected from surfaces interacts in a more positive manner. The result, especially with modest volume levels, will be intelligible, crystal clear audio reproduction, at an even level across the space. (It's worth noting that this energy cannot overcome the laws of physics – if sound is played very loud, then the cacophony will become more evident). Again not only have we now got excellent sound, we have no visible sound source to clutter decoration lines and no corrosion or degradation issues.

home theatre, think again!

# Simple to Install...

IN NEW BUILD OR RETROFIT APPLICATIONS, SIMPLY FOLLOW THE STEP-BY-STEP INSTALLATION GUIDE BELOW:

## Installation method for stud and dry wall sections and ceilings



1  
Create wall opening between studs the same size as the product by using a utility knife, making a series of shallow cuts. Add sound insulation into cavity. Ensure cables are pulled into position.



2  
For optimal visual results, mark a second perimeter line approx. 3/4 inch outside the perimeter of the product aperture and score at an inward angle just through the dry wall paper surface, or skip to # 4.



3  
Remove the paper around the perimeter of the aperture, and chamfer with sanding block or scraper to recess 1mm below surface, allowing for a completely flush installation.



4  
Fix installation blocks at each corner using two drywall screws secured through the front of the plasterboard in to the plastic lug provided. Connect loudspeaker cable and test operation.



5  
Secure product to installation block with one dry wall screw through the mounting hole at each corner of the product. Adjust screws to ensure front surface of loudspeaker is 1mm to 2mm behind the dry wall surface.



6  
Apply a coat of PVA adhesive to the surface of the panel loudspeaker and to the area of dry wall stripped back around the product's perimeter. Allow to dry for a few minutes.



7  
Using a taping knife or decorator blade, push dry wall compound down between the edge of the panel frame and the drywall opening, filling the perimeter gap to create a filled, level backing for the tape to adhere to.



8  
While the compound is still wet, apply mesh or paper joint tape around the perimeter of the product, straddling the product and the stripped-back dry wall making sure not to overlap the paper edge of the drywall.

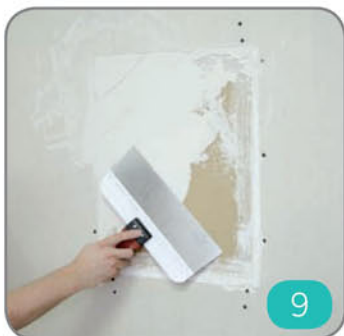

9  
Apply skim-coats of dry wall compound across entire panel surface and the area of stripped back dry wall and at least 6 beyond the seam to minimal 3/16th (2mm) thick. (this might take 2 or 3 applications, let dry in-between).



10  
Achieve fine finished surface by sanding back/filling any lower spots and feathering the edges to create an undetectable transition. Paint or wallpaper surface with decoration of choice.



### Installing in Stud walls or Ceilings

For increased fire barrier protection and to create additional rear-ward sound isolation use the 70mm deep Backbox FS.



### Installing in Solid walls

For block and solid wall structures, create a 45mm aperture and embed the Aina AIIUX Backbox SW ready for fitting the loudspeaker prior to plastering.

# The ultimate WOW factor!

Yes, this really is plastered over!...

## The Product

The advent of high power vibrational element flat panel loudspeakers has given birth to the truly unseen loudspeaker. This plastered in-wall (or in-ceiling) product type reproduces high definition sound with zero visual interference to room aesthetics. Entertainment systems can now be employed in every room of the home, whilst avoiding all the usual techno clutter. This technology has the additional advantage of improved dispersion characteristics over a conventional loudspeaker, making speaker location and listening position much more flexible.

The width of an AIWUX product allows it to fit well within the 400mm (16") between centre spacing commonly used in modern wood or metal studwork construction methods. However, if you have an unusual structure, Amina can provide installation advice and special sizes.

## Applications

The AIW1X is an affordable, concealed sound source for use in all parts of the home where more modest sound levels are called for. From bedrooms and bathrooms to kitchens and hallways, it reproduces high quality audio without compromising style or design.

The AIW3X is for use in all parts of the home including the main listening areas or home theatre, where good high levels of sound are required.

The AIW5X can be reserved for those special areas of the home, e.g. home theatre rooms, where very loud, highly dynamic, high performance reproduction is required.

In home theatre and other extended frequency range listening applications, the addition of a sub woofer to your system is recommended.

For those with monster taste in music or movie loudness, simply apply more than one AIW5X per channel.



SPECIFICATIONS	AIW1X	AIW3X	AIW5X
Nominal impedance	8 ohms	8 ohms	8 ohms
Power handling: Continuous	20w	40w	80w
Sensitivity (with 1.5mm plaster skim)	82dB 1m/1w	84dB 1m/1w	87dB 1m/1w
Maximum SPL (with 1.5mm plaster skim)	95dB 1m/20w	99dB 1m/40w	105dB 1m/80w
Frequency range	100Hz to 20KHz	100Hz to 20KHz	100Hz to 20KHz
Electrical connection	Butt splice crimp or 2 part polarised connector		
Dimensions	450 x 345 x 40 mm (17 <sup>3</sup> / <sub>4</sub> x 13 <sup>5</sup> / <sub>8</sub> x 1 <sup>5</sup> / <sub>8</sub> "	450 x 345 x 40 mm (17 <sup>3</sup> / <sub>4</sub> x 13 <sup>5</sup> / <sub>8</sub> x 1 <sup>5</sup> / <sub>8</sub> "	450 x 345 x 40 mm (17 <sup>3</sup> / <sub>4</sub> x 13 <sup>5</sup> / <sub>8</sub> x 1 <sup>5</sup> / <sub>8</sub> "
Product weight	910g (2 lbs)	1175g (2.6 lbs)	1810g (4 lbs)
Minimum aperture depth	60mm (2") from front of panel		
Fixings provided	Suitable for 12.5 & 16mm (1/2" and 5/8") thick Plasterboard		
Box quantity	Pairs	Pairs	Pairs
High pass filter requirement	100Hz at 24dB/Octave (Minimum external required e.g. Amina APU2 protection device)		

For the very best results, your system electronics should also comprise in-line equalisation to compensate for slight variations in frequency response due to plaster depths and wall types.

If you thought having great sound in the bedroom would be overpowering, think again!

Amina Technologies Ltd is the world's leading designer and manufacturer of flat panel loudspeaker systems. We supply high definition sound solutions for voice reinforcement and live music reproduction in the professional audio industry, and for high performance audio systems in the home. From boardroom AV systems to Broadway theatres, from centres of worship to museums of work and war (Jersey) and from the film set of Phantom of the Opera (Pinewood Studios, London) to the film showing in your home cinema, Amina has the discreet audio solution for architects, interior designers and all design conscious clients. See our web site for more details on the company and some of the prestigious projects that use our products.

Amina Technologies Ltd  
Cirrus House, Glebe Road, Huntingdon, Cambridgeshire, England, PE29 7DX  
**tel** +44 1480 354390 **fax** +44 1480 356564  
**email** inspired@amina.co.uk **web** www.amina.co.uk

Amina Technologies NA Ltd  
8044 Montgomery Rd, Suite 700, Cincinnati, OH 45236, USA  
**toll free** +866.GO.AMINA (866.462.6462)  
**tel** +001 513 677 1880 **fax** +001 513 677 8464

Amina Technologies NA Ltd  
286 Columbus Road East, Oshawa, Ontario, Canada, L1H 7K4  
**tel** (001) 905 655 6411 **fax** (001) 888-329-2491  
**email** sales@aminatechnologies.com **web** www.aminatechnologies.com

Your Amina Dealer:

#### Warranty

All Amina In-wall loudspeakers are guaranteed against defective workmanship for ten years.

Under our policy of continuous improvement, we reserve the right to change specifications without prior notice.  
E&OA

Easi-fill is a trademark of British Gypsum Ltd  
Amina is a registered trademark of Amina Technologies Ltd  
SoundUnseen<sup>®</sup> is a registered trademark of Amina Technologies Ltd  
Document: AIWI literature Revision 5.0USA  
Copyright, Amina Technologies Ltd, 2009

Printed in North America

*Impressive location,  
impressive  
and unseen  
entertainment  
system*



*“sound has never looked so good....”*